

ASUSat 1 Communications

Student Author: Laura A. Knauth

Faculty Advisor: Dr. Helen Reed

Aerospace Research Center
Arizona State University
Tempe, Arizona 85287-8006

Fourth Annual Student Scholarship Competition
In association with the
Tenth Annual AIAA/USU Small Satellite Conference
September 16 through 19 1996
Utah State University
Space Dynamics Laboratory

ASUSat 1 Communications

Student Author: Laura A. Knauth¹

Faculty Advisor: Helen L. Reed²

Arizona State University

Tempe, Arizona 85287-8006

Abstract

An overview of the communications components involved in the ASUSat 1 mission is discussed. The ASUSat 1 satellite will communicate with the Arizona State University ground station via an RF link in both a digital and analog mode in two amateur radio bands. In this way, ASUSat 1 will function as a voice repeater for the AMSAT community as well as to provide digital packet communications for the purpose of transferring data between the satellite and the ground station.

Nomenclature

AGC	automatic gain control
AM	amplitude modulation
AMSAT	Amateur Satellite
DTR	data to receive
EMI	electromagnetic interference
fc	frequency carrier
FM	frequency modulation
GMSK	Gaussian minimum shift keying
G/T	system gain divided by the equivalent system temperature
Gt	transmitter gain
Gr	receiver gain
IC	integrated circuit
IF	intermediate frequency
K	Boltzmann's constant
LO	local oscillator
Pr (dB)	power received
Preamp_gain	signal gain due to the preamplifier
Pt (dB)	power transmitted
PTT	push to talk
RF	radio frequency
RX	receive
Rx_coax_loss	signal loss in coaxial cabling

	while receiving
TX	transmit
Tx_coax_loss	signal loss in coaxial cabling while transmitting
UHF	ultra high frequency
VHF	very high frequency

1.0 Introduction

The ASUSat 1 satellite project was started by students attending Arizona State University in October 1993. The goal of the ASUSat 1 project is to prove the technology of the student-designed components and provide low cost imagery with a weight restriction of approximately 4.5 kilograms. This satellite will initially have a 550 km altitude 10:30 am - 10:30 pm sun-synchronous polar orbit. ASUSat 1 will be placed in orbit by an Orbital Sciences Corporation (OSC) Pegasus XL rocket with a planned launch date in March of 1997.

The primary goal of the ASUSat 1 communications team is to provide an RF uplink and downlink between the ASUSat 1 satellite and the ASU ground station. This link must be very reliable for the duration of the communications window which was calculated to be approximately nine minutes. In addition to achieving this goal, several constraints were placed on the communications team. None of the components on the satellite were to exceed 7.5 V, and the total weight of all

¹NASA Space Grant Intern
Junior, Electrical Engineering

²Associate Director, ASU/NASA Space
Grant Program; Associate Fellow, AIAA

communications components onboard was restricted to less than 385 grams. All of the onboard communications components consisted of two receivers, a transmitter, a modem, two antennas and their connectors, and an RF splitter. The onboard transmitter, modem and switching network had to be student designed to meet the voltage and weight requirements for the satellite. Both the transmitter and the modem weigh under 160 grams and use only 5 V and 7.5 V lines for power.

Since communicating with ASUSat absolutely essential to the mission, two receivers will be used, not only for redundancy purposes, but also to aid in locating the satellite once it has been deployed from the Pegasus rocket. There will be two possible uplink frequencies used to contact ASUSat 1 since there are two receivers on board, one for AMSAT communications and one to be used by the lab at ASU to receive data and telemetry information from the satellite. Figure 1 is a pictorial representation of the method by which ASUSat 1 will communicate with the ground station.

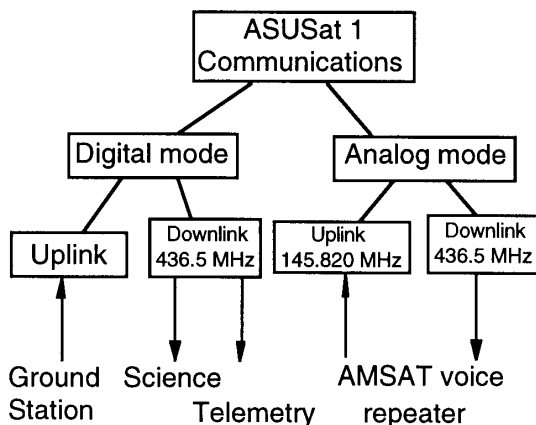

Figure 1: ASUSat 1 Communications

2.0 Flight Segment

The flight segment of the communications team includes the communications components located within the satellite. Figure 2 is representative of the data flow through each of the components that occurs during the operation of the communications

flight segment. The components of the flight segment will be discussed in detail in this portion of the document.

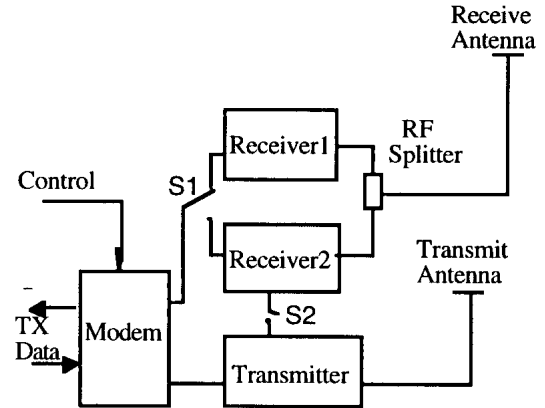

Figure 2: Flight Segment

2.1 Receiver Boards

Two receivers, constructed from Motorola's P-50 transceiver boards, will be used for this satellite. Both receivers use double conversion before reaching the base band and requires 5 V to operate. These receivers use 0.2 watts in stand-by mode or use 0.5 watts when they receive the threshold signal of 30 μ V. While both VHF receivers will be operating in the 145 MHz band, each of the receivers will be tuned to receive two distinct frequencies. One receiver, the "ASU receiver," will be used solely to receive digital packet transmissions from the ground station in the lab. These transmissions will use direct frequency modulation in the J mode with HDLC protocol at 9600 baud.

The other receiver will be opened to the AMSAT community as a voice repeater with J mode frequency modulation. The frequency for this voice communication has been set to 145.820 MHz.

The transmitters of each board will be disabled and two crystals and a coupling capacitor will be added. The transmitter can be disabled by removing a specific NPN transistor or disabling the 5 V TX line from the 14-pin connector on the board. These receivers will consume 0.2 watts in stand-by mode and 0.5 watts when receiving a

threshold signal of 30 μ V. Of the two crystals that will be added, one is used for the local oscillator and the other is used for the second IF mixer. The second IF mixer is set at 17.9 MHz for the 2 meter band always. The frequency for the local oscillator is based on the formula $f_c = (\text{carrier} - 17.9) / 3$. The weight of each board after all alterations is approximately 25 grams.

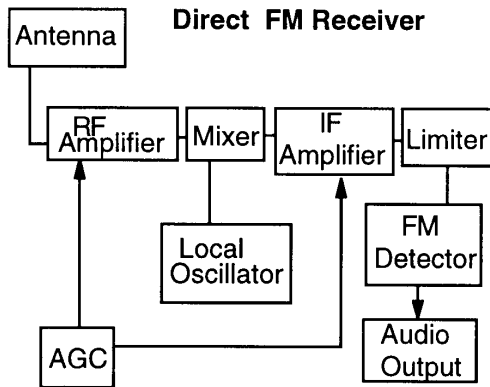

Figure 3: Receivers

These boards contain adjustable inductors which will be set in accordance to testing results. Once the values for each of the adjustable components have been determined and set, the tuning slugs will be secured with the encapsulant Dow Corning 93-9500 to prevent any alterations in the settings due to the stresses the satellite will receive during launch. The Motorola P50 receiver boards do have a successful space history.

An off-the-shelf RF splitter will be used so that only one uplink antenna is required for both receivers. This component will then reduce the weight and complexity of the communications system by eliminating the need for another receive antenna. Each receiver weighs about 25 grams after modifications and the RF splitter weighs under 20 grams.

Each board along with the GPS board of the satellite will be encased in a box made of wire mesh. This EMI box will any stray electromagnetic these boards so that they will

not interfere with the commands board and other components onboard the satellite.

2.2 TransmitterBoard

The transmitter, operational in the UHF range, is student designed, and consists primarily of two Motorola integrated circuits, the MC13176D RF Transmitter IC and the MHW707-1 Power Amplifier IC, plus the discrete components required for biasing. The MC13176D is a Motorola IC designed to function as an RF transmitter in either an AM or an FM mode. For this satellite, the IC will function as an FM transmitter. The MHW707-1 is a power amplifier chip required to boost the RF signal coming from the MC13176D to a range of one to two watts. The signal is then fed into the transmitting antenna. Figure 4 is representative of the function of this transmitter.

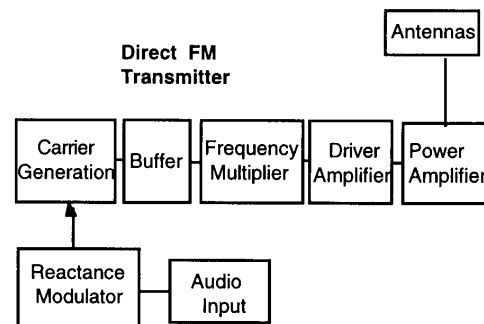

Figure 4: Transmitter

The transmit frequency is produced by an adjustable inductor and the MC13176D IC which provides current-controlled oscillation. This chip is capable of sinking 200 μ A and sourcing 50 μ A of current. With this current range, this chip is capable of varying the output frequency by 4.5 MHz. The input signal is divided by 32 by the IC and then compared to the frequency of the local oscillator (LO) which is configured as a common-emitter Colpitts crystal reference oscillator. The frequency of the LO is 13.5

MHz since $13.5 \times 32 = 435.2$ MHz, the downlink frequency. Once the input signal is adjusted to this LO, it is sent to the frequency multiplier circuitry where it is multiplied by 32. The transmitter then requires an additional 7.5 V to boost the power of the signal using the power amplifier and send the signal to the transmit antenna. An additional 5 V line is required to keep the transmitter crystal warm. This transmitter uses direct frequency modulation of a 436.5 MHz carrier and also produces narrow band frequency modulation.

Using the transmitter, the satellite will provide a digital packet beacon. This will aid in locating it after it has been deployed and also transmit telemetry information. Ham Radio operators from around the world will be able to assist in locating the satellite just after deployment. Until this first contact is made, the beacon will be sent every five minutes. The timing of this beacon may be decreased once contact has been established with the ASU ground station. The transmitter board weighs about 50 grams. Although this board has not been tested yet, qualification test will begin in the Fall of 1996.

2.3 Modem Board

The onboard modem operates at 9600 baud using Gaussian Minimum Shift Keying (GMSK), and will serve as an interface between the 85230 packet controller chip on the commands board and the transmitter or receiver by controlling the data flow using HDLC frame protocol. The modem along with the switching network weighs under 110 grams. The modem portion of the board needs a 5 V line, and the switching network requires a -5 V line.

When signal from the commands board is sent to the modem, the signal is first scrambled in order to cancel out the DC biasing of the logic levels in the signal. Once the signal has been shaped using Gaussian minimum shift keying (GMSK), the signal is cleaned using a low pass filtering scheme.

Figure 5 is representative of this data flow.

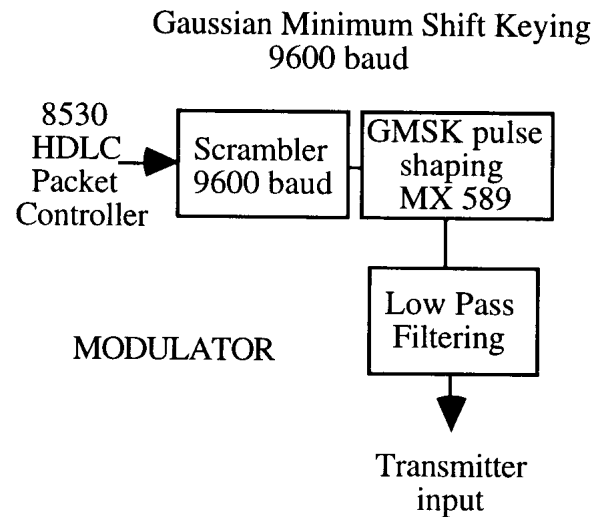

Figure 5: Modem Modulator

When a signal sent by the ASU Ground Station is fed into the modem by the receiver, the signal is cleaned via a low pass filtering scheme and then descrambled. Once the bits are synchronized with the clock, the data is sent to the 8530 HDLC packet controller on the commands board. Figure 6 is representative of this data flow.

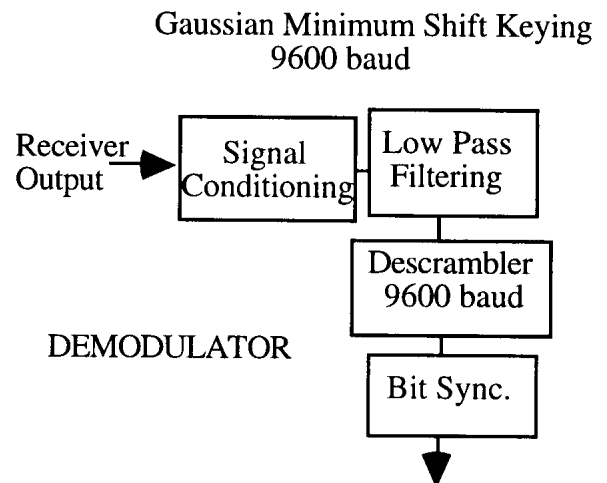

Figure 6: Modem Demodulator

Since this modem has been student designed, it has no space flight history. However, the modem has been tested and is operating successfully. The modem has also proved successful during integration testing with the commands board.

The modem board not only contains the modem circuitry, but also the switching circuit. The switching network consists of two switches S 1 and S2. The switch S 1 has two single-throw, single-pole switches, and S2 has four single-throw, single-pole switches. The three defined modes of operation are as follows:

During the DIGITAL mode ($S1=0$, $S2=0$), the output of the ASU receiver is connected to the input of the modem. The output of the modem is connected to the input of the transmitter. The DTR (data to receive) output from the commands board is connected to the PTT (push to talk) on the transmitter.

When the satellite is in VOICE mode ($S1=0$, $S2=1$), the output of the ASU receiver is connected to the input of the modem. The output of the AMSAT receiver is connected to the input of the transmitter, and the signal detect output on the ASU receiver is connected to the PTT on the transmitter. Due to power constraints, the VOICE mode will be disabled if the satellite is low on power, or if the receiver and transmitter have been active for long periods of time.

The final mode is the BACKUP RX mode ($S1=1$, $S2=0$). During this mode, the output of the AMSAT receiver is connected to the input of the modem. The output of the modem is connected to the input of the transmitter. The DTR output from the commands board is connected to the PTT on the transmitter. This mode will only be allowed if the ASU receiver fails. This mode will be activated by a software program if no transmissions have been made between the satellite and the ASU ground station within a period of three to five days. In essence, the AMSAT receiver is a redundant, or backup component.

2.4 Antennas

ASUSat 1 will operate in the two amateur satellite bands of 2 meters for the uplink and 70 cm for the downlink. This yields an uplink frequency of about 145 MHz and a downlink frequency of 436.5 MHz. Both onboard antennas will be constructed from

metallic tape with a width of half an inch. Both antennas will function as quarter wavelength dipoles which yield an approximate length of 22 inches for the uplink and 7 inches for the downlink. Both antennas will be tested in an anechoic chamber for impedance matching and their radiation patterns. Testing is done on each antenna to determine its exact lengths for the correct impedance.

Because these antennas can be best approximated using the ideal dipole model, the basic radiation pattern is known. The antennas will be omnidirectional since their radiation patterns will contain two lobes on either side of the antenna. The E-field radiates perpendicular to the axis of the antenna sweeping out a toroidal shape. The composite structure by itself or covered with thin aluminum foil on the inside will provide the necessary ground plane for these antennas. The gain radiated by the two lobes will be improved if the antennas radiate the signals perpendicular to the surface of the earth.

The antennas will be mounted onto the top bulkhead of ASUSat I using an OmniSpectra Microwave Sub-Miniature Type A (OSM SMA) Flange Mount Jack Receptacle and antenna mounting blocks made of TechTron Polyphenylene Sulfide (PPS) from the Polymer Corporation. The antennas will be oriented on the satellite so that they are tangent to the earth's surface. In order to reduce coupling or cross connection, the antennas are placed 180 degrees apart on the surface of the top bulkhead. Impedance matching was done in an anechoic chamber for each antenna. By reducing the thickness of the PPS between the antenna and the ground plane and increasing or decreasing the length of the antenna, the correct impedance match could be achieved at the proper frequency for the antenna so that the maximum power could be achieved with the antennas.

The theoretical gain during the uplink and downlink of the satellite communications was found using the RF Link Equation. This equation, which holds the same form for the uplink and the downlink, is as follows:

$$Pr(\text{dB}) = Pt(\text{dB}) + Gt Gr - 20\log(r) - 20\log(Tx_coax_loss) + \text{Preamp_gain} - 20\log(Rx_coax_loss) + 20\log(K)$$

For the uplink, the equation reduces to:

Power received = Power transmitted from the ground - free space loss - satellite G/T atmospheric losses - Boltzmann's constant.

The power transmitted from the ground station has to be normalized to include the antenna gain. The free space loss is the attenuation, or loss, of the signal as it travels through empty space. Atmospheric losses are caused by the reflection or other disruptions in the radio signal due to water molecules or other particles in the earth's atmosphere. Since these atmospheric losses are frequency dependent, the higher the frequency, the higher the loss.

The G/T is the gain over temperature, or the system gain divided by the equivalent temperature of the system. This system gain includes the antenna and preamp gain as well as the losses in the coax cabling running from the ground station to the antenna and the coax on the satellite linking the antenna to the receivers. The equivalent temperature of the system is inherent to the particular object according to its kinetic energy. For example, zero Kelvin would indicate zero kinetic energy and a noiseless system. The earth has an approximate equivalent temperature of 290 Kelvin. Therefore, from the satellite's point looking upon the earth, there is considerable noise. The G/T is used to compare the quality of a given antenna system. The measured G/T for the uplink equation is -31.57 dB/K. Although this is a relatively low G/T for the onboard antenna system, this deficiency is compensated for by the relatively high power of 25 watts of the transmission from the Ground Station. For the downlink, the G/T of the Ground Station antenna system was determined to be -12.3 dB/K. This is significantly better than G/T of the onboard antenna system. Therefore, the power of the transmitted signal from the satellite may be lower. ASUSat 1 will transmit at a power of 2 watts.

Using the RF link equation for the uplink, the total signal gain was determined to be 21.96 dB for a signal transmitted from the ground station at 25 watts. For the downlink equation, the signal gain was determined to be 11.7 dB for a signal sent from the satellite at 2 watts. These figures were calculated at a look angle of five degrees. These figure should improve dramatically all of the way until the look angle is 90 degrees. According to these figures, the ASU ground station should be able to effectively communicate with ASUSat 1 using this system.

3.0 Ground Segment

The term "ground segment" of the communications team is used to indicate all communications components located in the ASU Lab ground station. Figure 7 is representative of the flow of information from one component to another. Each of the components represented in the diagram will be described in detail in the following paragraphs.

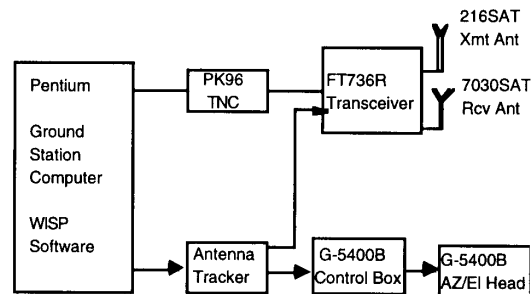

Figure 7: Ground Station

The ASU Ground Station is fully set up and is currently operational. This ground station has already been used to track existing satellites in orbit and the station is able to send and receive voice communications via an AMSAT voice repeater already in orbit.

3.1 Ground Station Computer and Supporting Software

The ground station computer is a pentium with 32 MB of RAM and a one giga-byte hard drive. The ground station computer has two RS-232 serial ports that will be utilized

for this project. One port will interface with the antenna tracker, and the other with the terminal node controller (TNC).

The computer will use a commercial software program called WISP to track ASUSat 1 once it is in orbit. The members of the ASUSat 1 team will input the updated Keplerian elements into the program as they are updated on the Internet by NORAD. WISP will then feed the information concerning the position of ASUSat 1 in its orbit to the antenna tracker, and the information about the Doppler shift in frequency to the transceiver. The Doppler shift in transmit and receive frequencies is caused as the satellite moves into or out of the communication window.

3.2 AntennaTracker

The antenna tracker used in the ground station has been manufactured by Endeavor Electronics. This device serves as an interface between the ground station computer and the transceiver and antenna rotator.

3.3 Antenna Rotator

The antenna rotator is an off-the-shelf item called the Yaesu G-5400B Antenna Rotator. This device has two components, the control unit and the rotator. The control unit is located in the lab and can be set to manual or automatic control of the ground station antennas. When the ground station is communicating with ASUSat 1, the automatic mode will be used so that the data output by WISP will directly control the antennas. The rotator is connected to the control unit by two six-conductor-cables. The rotator provides 360 degrees azimuth and 180 degrees elevation control of medium to large antenna arrays.

3.4 Antennas

There are two antennas mounted on the antenna rotator on the roof of the Engineering Research Center at ASU, one for the uplink and one for the downlink. The antennas are Oscar-link, off-the-shelf items and are composed of two separate circular polarized antennas, a fiberglass crossboom, necessary phasing lines, relay and hardware. Both

antennas include left and right circular polarization switching to reduce fading. For the 145 MHz band, the 216SAT antenna is used. This antenna has a bandwidth ranging from 144-148 MHz which includes the uplink band that ASUSat 1 will use as well as some leeway for the Doppler shift that will occur. This antenna has 16 elements, a gain of 11.5 dBc, and a front-to-back ratio of 25 dB. The 7030SAT antenna will be used for the downlink in the 435 MHz band. This antenna has a bandwidth ranging from 432-438 MHz which also encompasses the desired frequency for ASUSat 1 and allows for variations in frequency due to the Doppler shift effect. This antenna has 36 elements, a gain of 14 dBc, and a front-to-back ratio of 25 dB.

Signals will travel from the antennas to the ground station in the lab via plenum rated cables. Although there will be line losses, this will be compensated by the addition of a mast-mounted preamplifier which will provide a 10-15 dB gain. In order to reduce the amount of feedback that will come from interference with the roof of the ERC, the antennas were mounted on a ten-foot mast above the roof.

3.5 Transceiver

The Yaesu FT-736R Transceiver is a VHF/UHF full cross band duplex transceiver designed for satellite operation. It operates in the VHF range from 144-177.99999 MHz and in the UHF range from 430-449.99999 MHz with a maximum capability of 25 watts of power output for both bands. Both ranges include the frequencies necessary for communication with ASUSat 1. Receive sensitivity is -9 dBu for 12 dB SINAD in both bands for FM, and the image rejection is 60 dB or better. The bandwidth of the IF filter has been increased to 15 kHz to allow for 9600 baud packet operation.

When communicating with ASUSat 1, the transceiver will transmit information input into the ground station computer at the frequency specified by the antenna tracker. This frequency will differ continually during

the communication window due to the Doppler shift effect. The transceiver will receive the signals sent by ASUSat 1 by amplifying the frequencies received in the threshold provided also by the antenna tracker. When a signal from this threshold has been received by the transceiver, it will be passed to the TNC.

3.6 Terminal Node Controller

The ground station uses the AEA PK96 Terminal Node Controller. This device functions not only as a terminal node controller, but also as a modem. Once a signal is sent from the transceiver to the TNC, the signal is demodulated, stripped of its flags and checksums, and sent into the ground station computer. When a signal is fed from the computer to the TNC, the signal is modified via HDLC protocol, modulated and then sent to the transceiver whereby it is sent to the orbiting ASUSat 1.

4. Conclusion

Using student designed modem and transmitter boards, the communications team was able to meet voltage and weight requirements. Unlike expensive, large, and heavy directional antennas, the antenna system designed by this communications team was extremely light, small, and lowcost. In addition to the structural and financial benefits to the onboard antenna system, the antennas were designed to be omnidirectional which allows for much leeway in the satellite's orbit. For example, if the dynamics team is unable to stabilize the satellite's oscillations, it will still be possible to communicate with ASUSat 1 using the antenna system this team has designed. The use of two receivers allows for the satellite to operate in two distinct modes of communication providing not only versatility, but also extra reliability. The innovative system design, electronic boards, and antenna system allows ASUSat I to better carry out its mission while simultaneously meeting all system requirements.

5. Acknowledgments

The author would like to acknowledge Keith Tinsley, Richard Bertapelli, Mike McKittrick, and especially Clarence McAllister for their advice, knowledge, and expertise on the ASUSat 1 communication system that has significantly added to the content of this paper. The author would also like to acknowledge Joel Radamacher for his insight and management skills that has made the ASUSat 1 project possible.

Support for the ASUSat 1 team, in the form of mentoring and assessment, hardware donations, student support, and use of fabrication and testing facilities has been secured as follows.

Orbital Sciences Corporation -- Pegasusrocket launch, advising, test facilities

NASA Space Grant Program -- student internships and fellowships

National Science Foundation Faculty Awards for Women in Science and Engineering -- student funding

AMSAT Organization -- communications frequencies and extensive advising

Honeywell Space Systems Group -- advising in all areas

Motorola (Satcom & University Support) -- thermal, power, and communications advising, IC, crystal, and receiver donations

Intel (University Support) -- processor, literature, In-Circuit Emulator (ICE), test equipment donations

PhotoComm, Inc. -- solar array advising and facilities

Universal Propulsion Company, Inc. -- advising, explosive bolt cutter donation

ICI Fiberite Composites -- advising, composite material

DynAir Tech of Arizona -- advising, autoclave usage, composite material, facilities for manufacturing parts

ASU/Architecture & Environmental Design Shop -- machining facilities

ASU/Electrical Engineering Department loan of testing equipment

National Technical Systems environmental testing

SpectrumAstro -- communications testing

Trimble Navigation -- GPS board and antenna, advising

AERL (Australia) -- peak power tracker

Bell Atlantic Cable -- ground station antenna cabling

Lee Spring Company -- prototype deployment springs

Astro Aerospace -- advising, boom material donation

Simula, Inc. -- structural-analysis advising

BekTek -- software advising

KinetX -- advising on software and ground support

Equipment Reliability Group -- advising on testing equipment

Jet Propulsion Laboratory -- non-flight transmitter donation

Rockwell -- non-flight solar-cell donation

Sinclabs, Inc. -- non-flight test antenna donation

Hughes Missile Systems -- advising, electronics troubleshooting

Applied Solar Energy Corporation -- discounted hardware, advising

Eagle Picher Industries -- advising (battery algorithm), batteries

Gordon Minns and Associates -- on-board cameras

Space Quest -- communications advising